

Thermal Simulation of Chemical-Synthesized Thick Film as Thermal Interface Material in Downlight LED

Mah Jian Wen, Shanmugan Subramani, Mutharasu Devarajan
Universiti Sains Malaysia, Nano-Optoelectronics Laboratory, 11800 Minden, Pulau Pinang

Introduction: With the increasing usage of LED in the lighting application, heat dissipation of the LED in a package has caused much problem to the lighting device itself. As the light output of the LED is strongly dependent on the thermal performance, thermal interface material (TIM) has become an area of interest that can be used to sink more heat out to the ambient. This TIM is fabricated from the screen printing method, by mixing Zinc Oxide powder (ZnO) with optimized ratio of binder and polymer. From the synthesis, different TIMs are produced. The thickness of each TIM is measured. The material properties of the different synthesized TIM are characterized by using Thermal conductivity machine, supplied by Perkin Elmer. By combining thickness, different material properties from the synthesized TIM, and the applied current to the LED, the downlight LED was developed into application mode for end-user to study these phenomenon.

Material Property	S1	S2	S3	S4	S5	Unit
Density	999.0	977.6	2512	2859.2	3880	Kg/m ³
Thermal Conductivity	0.433	0.699	1.240	1.350	0.800	W/mK
Heat Capacity	1059.7	1259.7	1460.7	1559.8	1560.8	J/kgK

Table 1. Material Properties of Different Binder Ratio

Results: From the simulation, the variation of binder ratio in TIM, has affected the structural orientation of the TIM, which contributes to different material properties. Thermal conductivity has increased and found to reach the optimum at sample S4, where the maximum heat is dissipated.

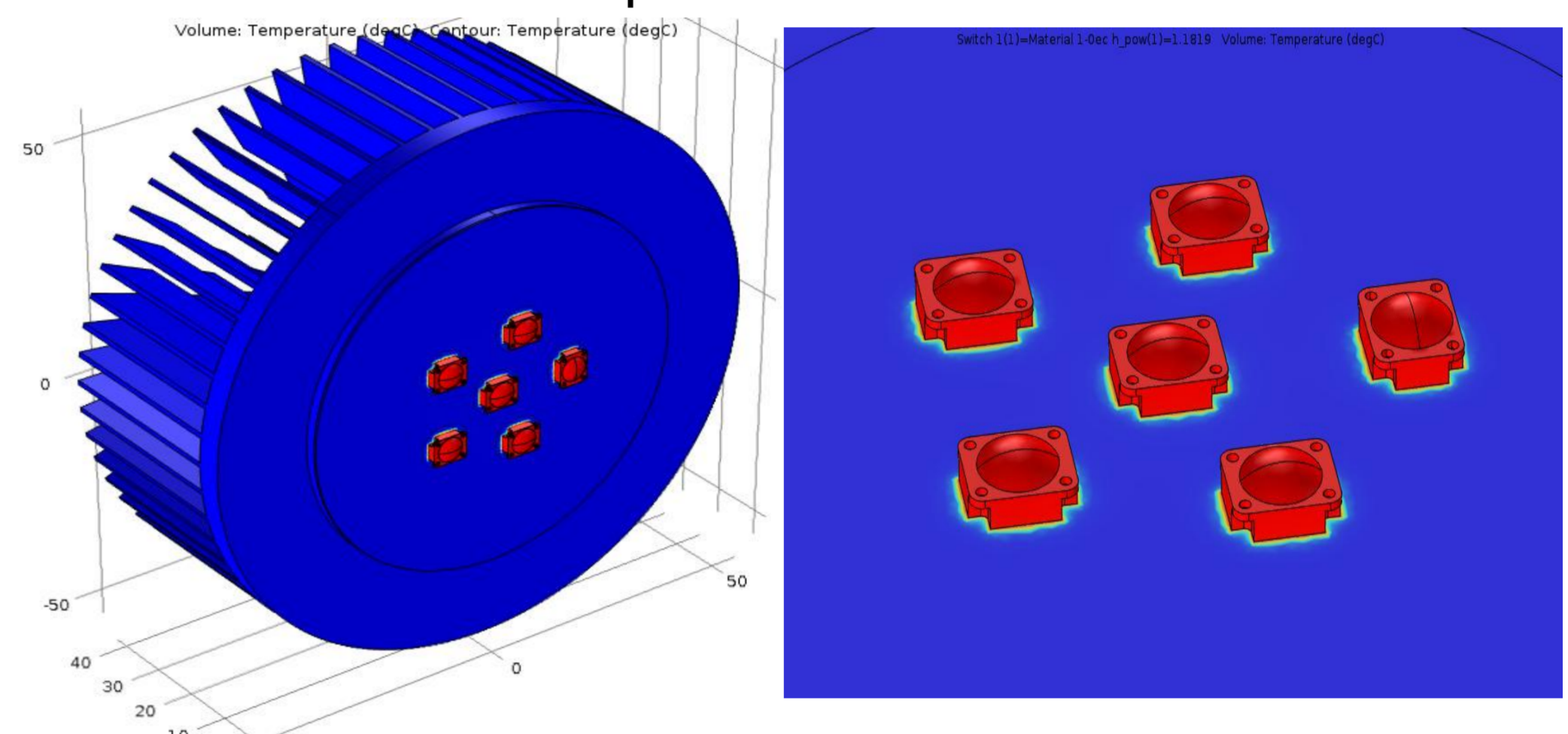

Figure 3. Thermal Distribution at each LED relative to TIM

Applied Heat Power/W	S1	S2	S3	S4	S5
1.18185	25.9	23.7	22.2	22.1	23.3
2.18185	30.9	26.9	24.1	23.8	26.1
3.18185	35.9	30.1	26.0	25.5	28.9
4.18185	40.9	33.3	27.8	27.3	31.7
5.18185	45.9	35.4	29.7	29.0	34.5
6.18185	50.9	39.6	31.6	30.8	37.3

Table 2. Maximum Temperature of Different Binder Ratio

Conclusions: With COMSOL Multiphysics, the material properties of the synthesized TIM and thermal performance can be directly simulated before prototyping. In future, we can use this module to examine more prototype before manufacturing.

References:

1. Minseok Ha, Samuel Graham, Development of a thermal resistance model for chip-on-board packaging of high power LED arrays, Microelectronics Reliability 52 836–844 (2012).

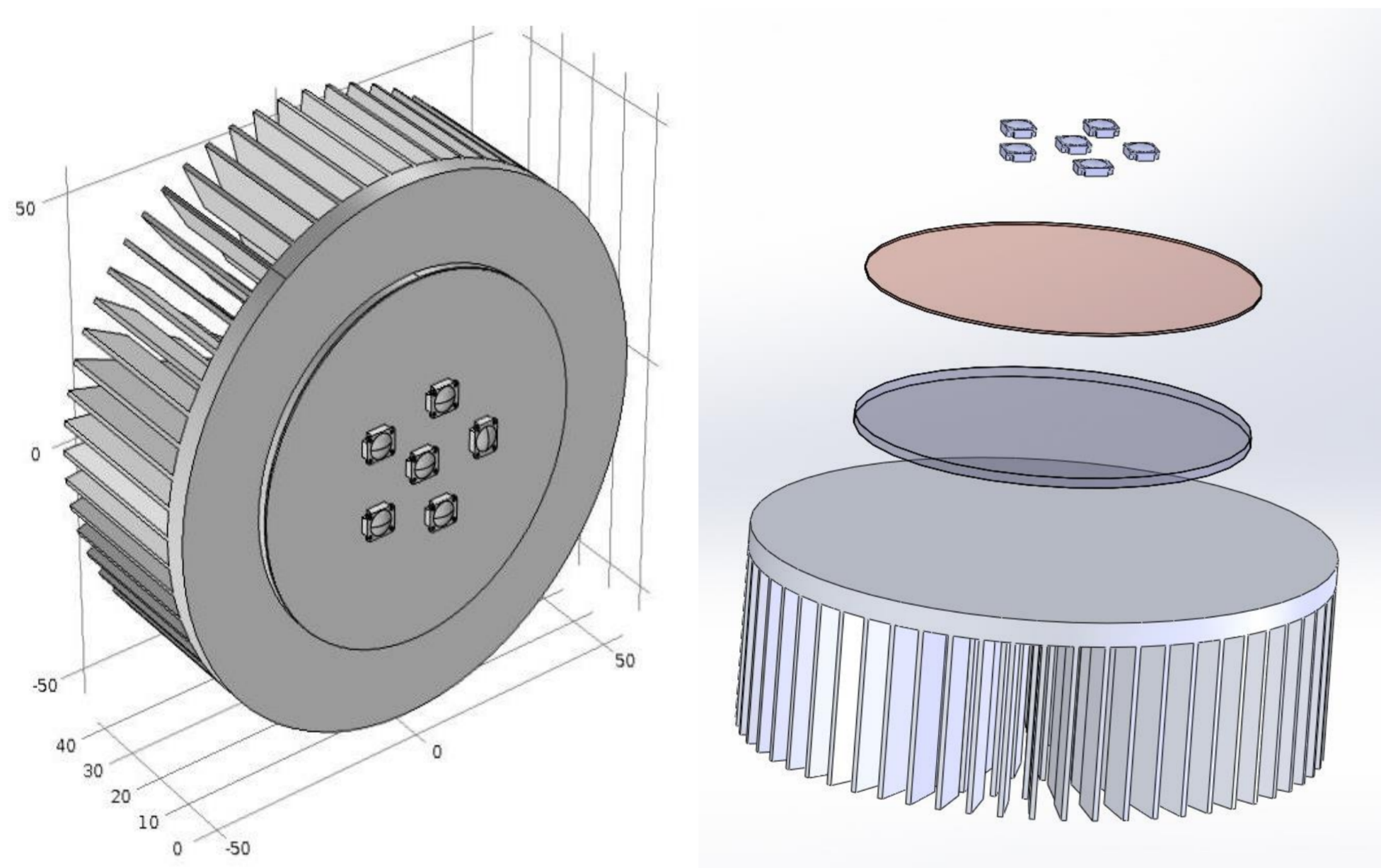

Figure 1. Simplified CAD Geometry with different layer

Computational Methods: Computing the heat transfer in solid for the design geometry at stationary stage, equation below is used.

$$\rho C_p \mathbf{u} \cdot \nabla T + \nabla \cdot \mathbf{q} = Q$$

Where ρ is the density of the material, C_p , is the heat capacity at constant pressure, supplied at heat source, Q , with the change of temperature, T . The thermal conductivity, k , explains the relationship of vector heat flux, \mathbf{q} and the temperature gradient, ∇T as below.

$$\mathbf{q} = -k \nabla T$$

In this simulation, material sweep and parametric sweep are used to study the heat transfer from LED package to ambient. Different material properties and applied heat power are shown in Table 1 and 2. Thickness of TIM is constant throughout the simulation.