

Consider the following systems. Identify a suitable space dimension to solve them in, and which interfaces should be used, based on the rules discussed. When the system is best simulated in 2D or 2D axi-symmetry, the plane the model is solved in should also be identified:

- 1) A square cross-section toroid filled with water, with the centreline passing along the z-axis. A current is passed radially between the inner and outer walls. A uniform background magnetic field points in the z-direction.

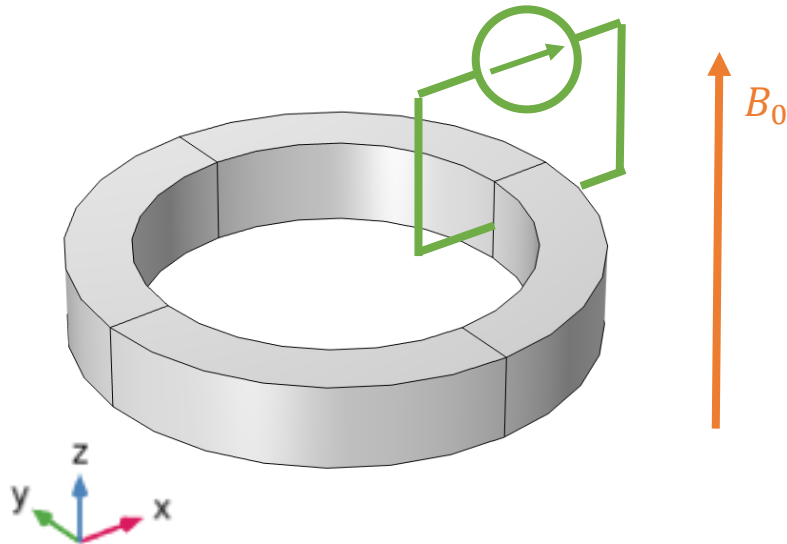

- 2) Flow of mercury between two infinitely large parallel conducting plates. The flow is driven by a pressure gradient dp_0 along the x-axis, and a uniform background magnetic field is directed between the plates along the z-axis.

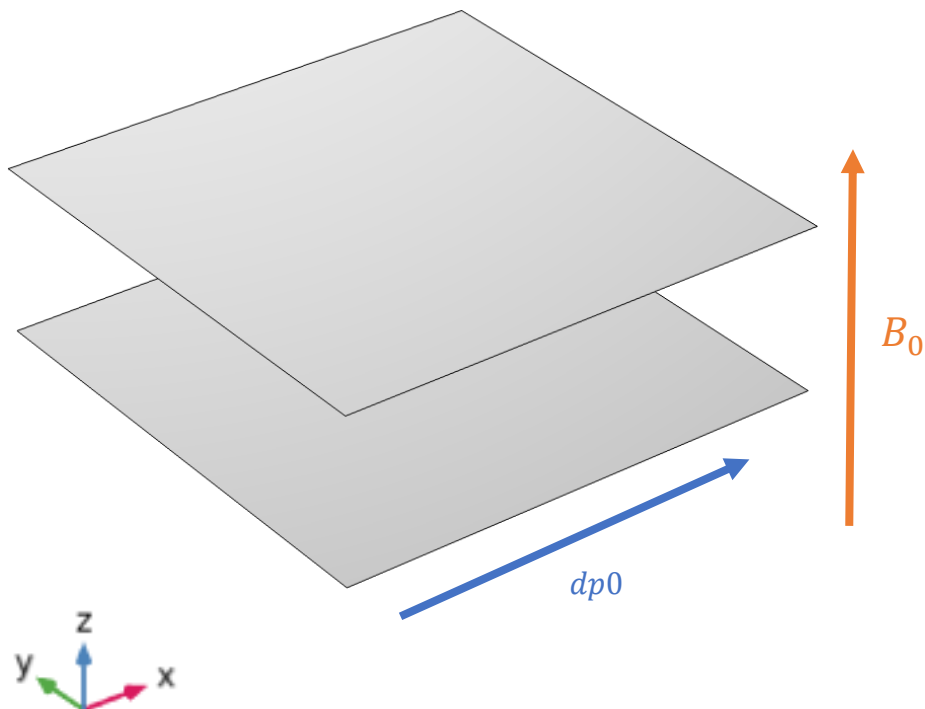

- 3) A pipe carrying fast-flowing water is placed between two current carrying coils acting as electromagnets.

